

商佑不銹鋼防震接頭

STAINLESS STEEL FLEXIBLE JOINT

▲SF-600 系列

◎ 應用

適用於空間受限制及較大偏心的場合，一般使用在排氣軟管、鍋爐用熱水管、蒸汽管、給水管、消防管的震動吸收。

◎ APPLICATION

Apply in limited space and larger offset, generally using in shock absorption of exhaust flexible pipe, hot water pipe, steam pipe, water service pipe and fire-fighting pipe.

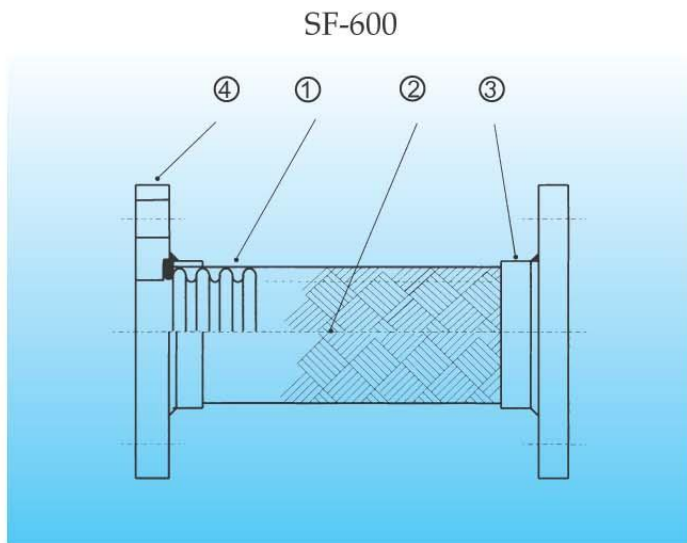

◎ 構件 CONSTRUCTION

ITEM	PARTS	MATERIAL	REMARK
1	BELLOWS	SUS304	SUS316
2	WIRE BRAIDS	SUS304	
3	SEAL RING	SUS304	SUS316
4	FLANGE	SS400	SUS304 / SUS316 A105

FLANGS TYPE : JIS, ANSI, BS, DIN

◎ SF-600 系列性能規格表 SPECIFICATION

◎ 下述工作壓力以常溫25°C為基準

Nominal Bore 口徑		Total length 總長度		Bellow		Lateral Movement 容許變位置(mm)		Working Pressure 工作壓力
mm	Ins	mm	Ins	O.D. 外徑	T 板厚			Kg/cm ²
15	1/2	200	8	30.5	0.3	40	26	20
20	3/4	200	8	30.5	0.3	40	26	20
25	1	200	8	38.0	0.3	38	24	20
32	1-1/4	200	8	46.0	0.3	36	21	20
40	1-1/2	200	8	56.0	0.4	33	16	20
50	2	230	9	73.6	0.4	28	15	20
65	2-1/2	230	9	88.0	0.4	24	13	16
80	3	230	9	102.0	0.4	20	11	16
100	4	230	9	128.0	0.4	18	9	13
125	5	280	11	155.0	0.5	23	14	10
150	6	280	11	185.0	0.5	20	12	10
200	8	300	12	235.0	0.6	20	8	10
250	10	330	13	286.0	0.6	17	8	10
300	12	350	14	340.0	0.7	15	7	10

※工作壓力及偏心量大於表中規格可另行設計、製造。

※口徑14"以上規格另行提供。

※上述規格表及板厚本公司可依需求作修正。

※ Working stress and offset quantity are larger than on the table of specifications, that can design and manufacture separately.

※ The specifications are more than caliber 14" to be provided separately.